

**DETAIL "A"**  
 PVC – ROCK/SOIL  
 FOR AREAS NOT TO BE PAVED

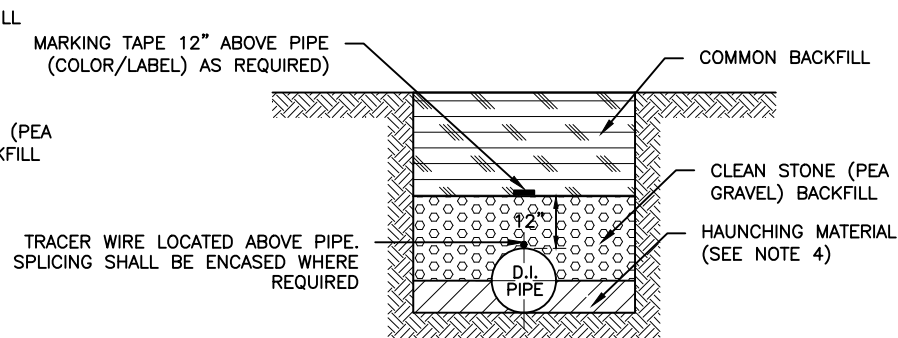

**DETAIL "C"**  
 D.I. – SOIL  
 FOR AREAS NOT TO BE PAVED

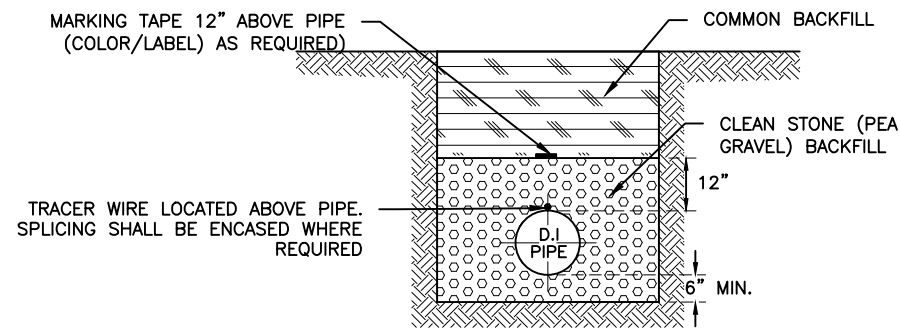

**DETAIL "E"**  
 D.I. – ROCK  
 FOR AREAS NOT TO BE PAVED

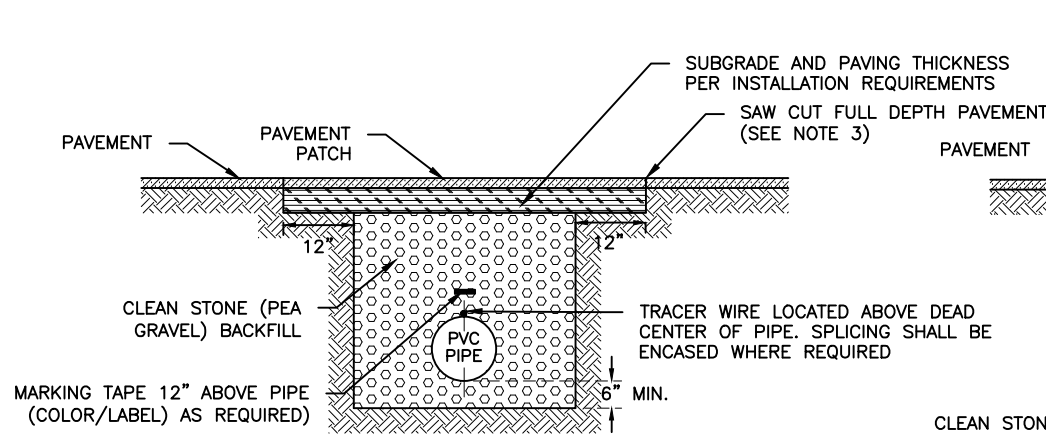

**DETAIL "B"**  
 PVC – ROCK/SOIL  
 FOR PAVED AREAS OR AREAS TO BE PAVED OR WITHIN 18" OF PAVING

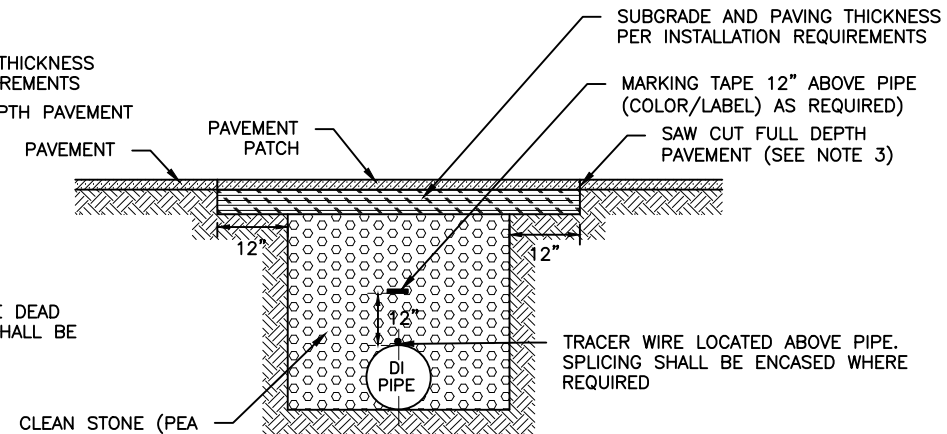

**DETAIL "D"**  
 D.I. – SOIL  
 FOR PAVED AREAS OR AREAS TO BE PAVED OR WITHIN 18" OF PAVING

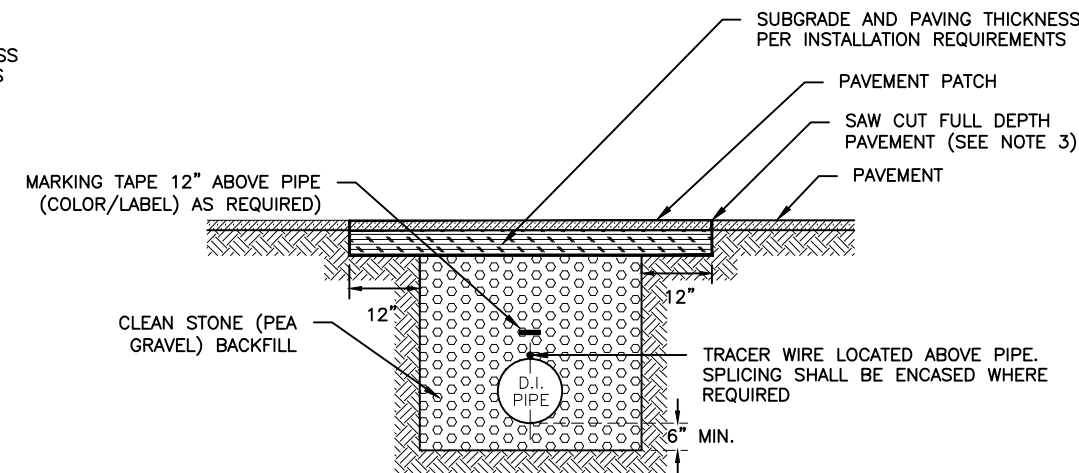

**DETAIL "F"**  
 D.I. – ROCK  
 FOR PAVED AREAS OR AREAS TO BE PAVED OR WITHIN 18" OF PAVING

**GENERAL NOTE:**

1. CAUTION MUST BE EXERCISED TO ENSURE PROPER PLACEMENT OF EMBEDMENT MATERIAL UNDER THE HAUNCHES OF THE PIPE.
2. POLYETHYLENE ENCASING ON ALL D.I. – PIPE, FITTINGS, VALVES & APPURTENANCES.
3. IF EDGE OF SAW CUT IS <= 4LF FROM CURB LINE, REMOVE PAVEMENT TO CURB.
4. STONE BACKFILL TO BE MECHANICALLY COMPACTED IN 6"-12" LIFTS.
5. REFER SPECIFICATION SECTIONS FOR DESCRIPTION OF BACKFILL AND BEDDING MATERIAL.
6. PROVIDE MINIMUM COVER OF 36" OVER ALL PIPE AND IN ACCORDANCE WITH ODEQ STANDARDS.
7. TYPICAL TRENCH WIDTH SHALL BE PIPE O.D.+2'.

REVISIONS 7/12 – MSG EDITS 12/13 – MSG EDITS 1/16 – MSG EDITS	AMERICAN WATER MILITARY SERVICES GROUP CIVIL TRENCH RESTORATION DETAIL
	AMERICAN WATER MILITARY SERVICES GROUP CAMDEN, NJ 08102
	AMERICAN WATER M.S.G. 1 WATER STREET CAMDEN, NJ 08102 DRAWN BY J. DERUSSO PROJECT ENG'R PDK APPROVED
DATE 05-17-2010 PROJECT N/A	USE DIMENSIONS ONLY SCALE N.T.S.
USE APPROVED DRAWINGS ONLY FOR CONSTRUCTION PURPOSES	MSG-ST-02-FS